



Product Guide

*Natural Material for Roofing Systems, Wall Cladding,
and Fascia & Coping Products Used in Architectural Applications*

IMETCO



Contents

About United Zinc	4
The <i>Only</i> Domestic Architectural Zinc - Processed and Formed in America	
Architectural Building Products by IMETCO	
Processing of Zinc Strip by Jarden Zinc	
Physical Properties.....	5
Alloy 710	
Physical and Mechanical Properties	
Backside coating	
Thermal Movement	
Self-healing	
Material compatibility	
Design Considerations	8
Finishes	
Memory	
Ventilation	
Roof Slope	
The Natural Patina Process and Preweathered Finishes	
Material Handling and Installation Guidelines	9
Temperature Considerations	
Packaging	
Soldering	
Handling	
Field Storage	
Construction Dust and Debris	
Protective Film	
Cleaning	
Caulks and Sealants	
Products Available in United Zinc.....	11
Series 300® Symmetrical Seam Metal Roof	
TwinLok Mechanically Seamed Metal Roof	
DLSS Architectural Metal Roof	
Latitude™ Wall Panel Systems	
FW Metal Wall Panel Systems	
PermWall Flush Metal Wall System	
PerformaEdge and EZ Edge Fascia & Coping	
United Zinc and Sustainability	15
LEED	
Environmental Considerations	
Durability/lifespan	
Recycled content	
Recyclability	
Energy demand (production)	
Run-off and Fungal Resistance	



About United Zinc

The Only Domestic Architectural Zinc - Processed and Formed in America

Since the early 19th century, zinc has remained a preferred roofing material throughout the world. Due to the material's natural beauty, sustainability and longevity, its popularity in the United States continues to grow.

Now United Zinc, the only domestically produced zinc available to the construction industry in the United States, is available exclusively from IMETCO.

United Zinc is timeless, durable, versatile and environmentally responsible. It is pre-treated for immediate aesthetic appeal and continues to develop its distinctive patina as it ages, which creates a durable, corrosion-resistant surface making United Zinc a long-lasting material suitable for most climates. It resists mold, mildew and fungus, but its runoff is "clean" and will not harm desirable vegetation like other exotic metals can. In addition to being non-corrosive and environmentally-friendly, United Zinc is virtually maintenance free; its self-healing nature can even make scratches disappear over time. In terms of recyclability, United Zinc not only has extremely high recycled content (more than 30% comes from recycled or secondary zinc), but it is also 100% recyclable and has a high scrap value.

United Zinc's versatility makes it an ideal material for a variety of design styles and applications.

Industry Leaders IMETCO and Jarden Zinc Partner to Bring You United Zinc

By leveraging the unique strengths of these partners, we are able to provide the highest quality domestic zinc architectural products with shorter lead-times while maintaining environmentally responsible manufacturing practices.

Architectural Building Products by IMETCO

IMETCO®, a recognized leader in the metal roofing industry for decades, offers a full range of high-quality performance-inspired exterior metal building products, including roofing systems, wall panels, fascia and coping, and a variety of accessories. IMETCO continues to produce its signature products while developing and introducing new products and services in response to the needs of the customers it proudly serves.

With exceptional service as its core value, IMETCO has experienced continuous and exponential growth since its inception. Its staff comprises experts in metal roofing, metal design, engineering, testing, code compliance, manufacturing, and more. Special manufacturing capabilities, such as curving, tapering, and field forming further distinguish IMETCO from other manufacturers. An in-house engineering team provides project support and produces custom project-specific shop drawings. Project managers work diligently to streamline the procurement and delivery of materials, and value-added production services help accommodate even the most aggressive installation schedules.

What truly sets IMETCO apart is the level of service and support provided to each and every customer, for at IMETCO, your satisfaction is our only measure of success.

Processing of Zinc Strip by Jarden Zinc

Jarden Zinc Products, a subsidiary of the Jarden Corporation, is the only producer of solid zinc strip for architectural applications in North America. At its 350,000-square-foot manufacturing facility located in Greeneville, Tennessee, Jarden casts and rolls 120,000 metric tons of finished solid zinc strip each year. Jarden uses only 99.995% pure special high-grade zinc with copper, titanium and other metals to craft alloys that are continuously cast and rolled into solid zinc strip in a variety of gauges that meets all EN 988 standards.

With the most stringent quality control standards in place, Jarden continuously monitors and tests to ensure a consistently produced high-quality zinc product that is used throughout the world for a variety of applications including coinage, automotive, electronic, cathodic protection, and architectural building materials.





Physical Properties

Alloy 710

Description

Architectural-grade zinc alloy consisting of 99.995% pure zinc combined with controlled amounts of copper and titanium to improve hardness, strength, ductility and creep resistance. Complies with EN 988 standard, which imposes strict requirements for the composition of rolled zinc.

Typical Uses

Architectural applications, painted or powder coated hardware parts, low amperage electrical conductor.

Composition (% by wt.)

Copper	0.10 to 0.25
Titanium	0.06 to 0.10
SHG (Special High Grade) Zinc (99.995% pure)	balance

Physical and Mechanical Properties

Density (lb/in ³)	0.259
Melting Point (°F)	792
Coefficient of Thermal Expansion (µin/in•°F)	15.4
Electrical Conductivity (% IACS)	26
Electrical Resistivity (Ω•cir. mil/ft)	39.58
Thermal Conductivity (BTU/ft•hr•°F)	60.5
Shear Strength (ksi)	24-28
Tensile Strength (ksi)	.21 to 28
Hardness (Rockwell 15T)	.50 to 68
% Elongation (in 2")	30-45
Yield strength	~ 28,000 psi
Min. Cold Form Bend Radius	.3T (up to 0.032" sheet thickness)
	.4T (over 0.032" sheet thickness)

Special Mechanical Test Parameters: Ref. ASTM B69-98a, Section 7.1.1: for Tensile Properties testing, the recommended rate of separation of the heads should be 0.125 in./in./min., which is equivalent to a cross head speed of 0.250 in./min.; and Section 7.1.2: for Hardness testing, the dwell time of the major load should be 15 seconds.



Backside coating

Unlike the external surfaces that develop a protective zinc carbonate patina, the underside of zinc is subject to corrosion from moisture accumulation in the absence of carbon dioxide and needs to be properly protected. Ventilation and a back-side barrier coating are effective means of providing this protection.

United Zinc features a high-performance backside coating to help protect the material from interior surface corrosion. This 5 mil plastisol coating significantly outperforms other common zinc coatings when subjected to abrasion testing. Due to the thermal expansion and contraction of zinc, superior abrasion resistance is critical to protecting the bare underside of zinc from premature corrosion that can be caused by condensation and trapped moisture.

ASTM D 968, Method A: Abrasion Resistance of Reverse Side Coating

	Backside Coating		Performance	
United Zinc	Plastisol	5.0mil tdft*	300+	Liters of Falling Sand
Competitor A	"Liquid Polymer"	2.4 mil tdft*	144 +/-	Liters of Falling Sand
Competitor B	Polyester	1.0 mil tdft*	40	Liters of Falling Sand

* Total Dry Film Thickness (TDFT)

Thermal Movement

Design limitations due to thermal expansion:

- Panel systems utilizing two-piece clips should be limited to 30-foot maximum length
- ¼-inch expansion required at all trim and flashing end laps
- Tile shingle and cassette profiles must accommodate thermal expansion at each joint
- Panel systems utilizing soldered end-laps should be limited to 10-foot lengths

Self-healing

Zinc's naturally forming patina is a protective layer of zinc carbonate, which provides decades of virtually maintenance-free protection. As zinc continues to renew this protective layer throughout its lifespan, any imperfections or scratches will naturally self-heal, minimizing the need for ongoing maintenance.

Thermal Movement in 30-foot Lengths at 160 Degree Fahrenheit Temperature Differential

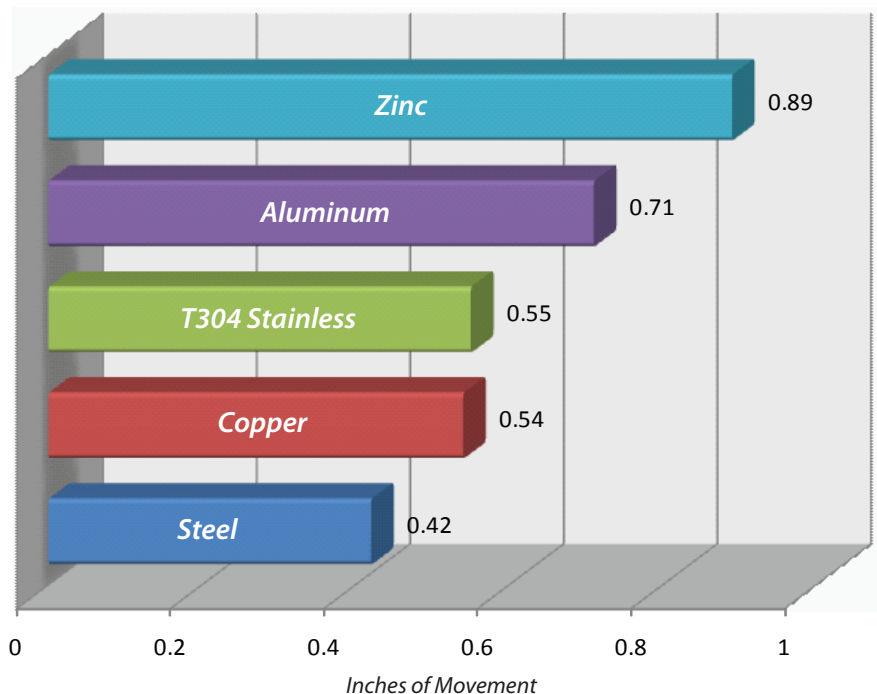

Material compatibility

Some materials can have detrimental effects on the appearance and integrity of zinc. Acidic products and products that can generate a galvanic reaction must not be used with zinc.

Compatibility with Other Metals

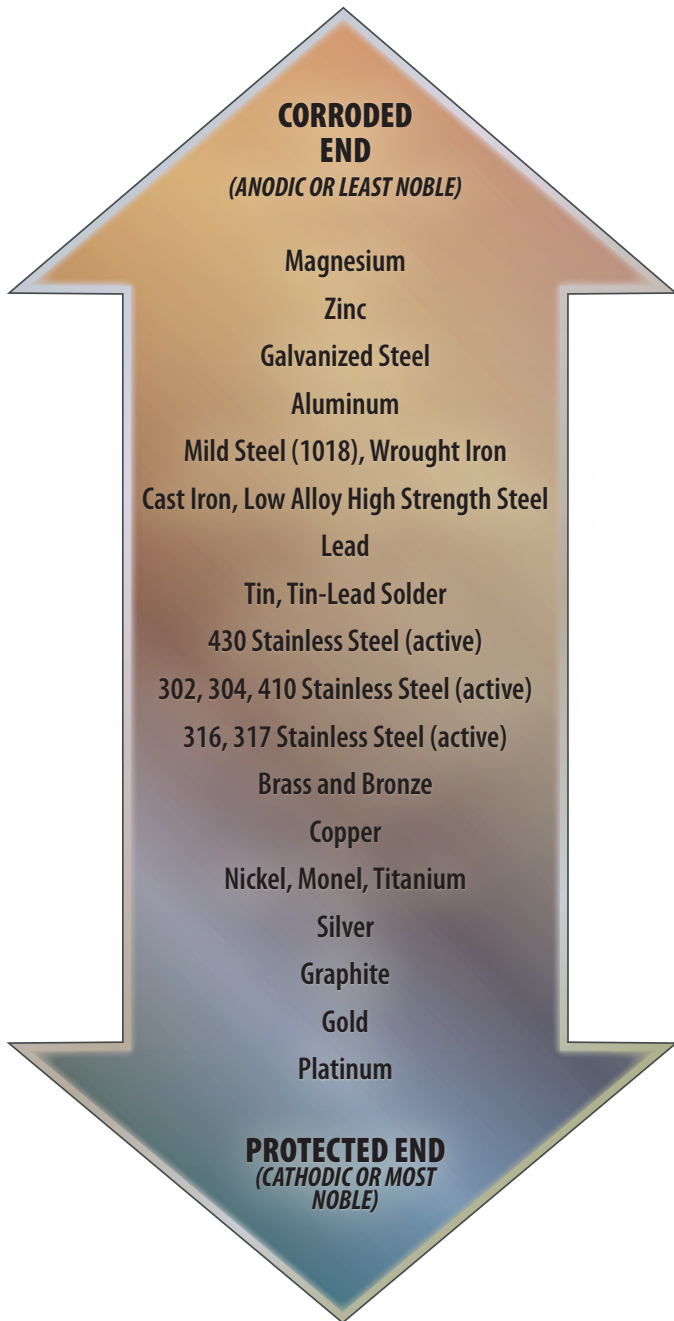

Electrical Potential between Zinc and other Metals

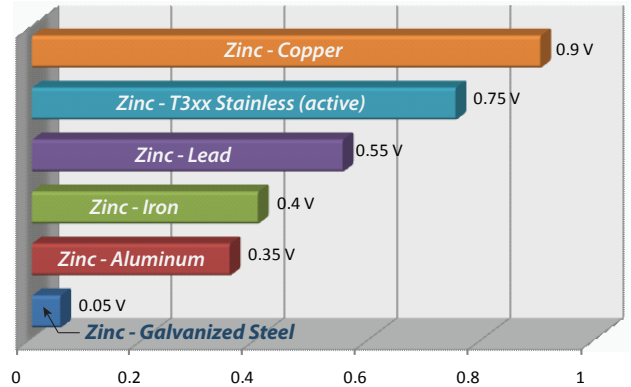

- For exterior environments (exposed to weather), there should not be more than 0.15 V electrical potential in the Anodic Index
- For exterior environments (concealed spaces) and interior spaces (non-temperature or-humidity controlled), typically there should not be more than 0.25 V electrical potential
- For interior controlled environments, 0.50 V electrical potential can be tolerated

Compatibility with Wood and Plywood

Zinc can be used with certain woods, such as poplar, spruce, and pine. More acidic woods (such as chestnut, Douglas Fir, oak, larch, birch and red, white and yellow cedar), should be avoided. Zinc should not come in direct contact with plywood or chipboard, as these products can contain acidic timber types, tannins, or phenolic adhesives, and do not absorb humidity or allow ventilation. All of these factors increase the risk of corrosion. If these materials are used, exterior quality treated plywood is recommended, and the zinc should be protected by a plastisol backside coating (standard on United Zinc).

Compatibility with Bituminous Felt

Zinc should not come in direct contact with bituminous felt due to the risk of water retention in the felt, which increases the risk of corrosion. If felt is used, the zinc should be protected by a plastisol backside coating that can withstand abrasion due to thermal movement (standard on United Zinc).

Compatibility with Concrete

Zinc should not come in direct contact with concrete or reinforced concrete. If concrete is used, the zinc should be properly ventilated and protected by a plastisol backside coating (standard on United Zinc).

Run-Off

Run-off from non compatible products onto zinc must be avoided. Run off from a copper surface to a zinc surface must be avoided under all circumstances. In general, water should not be allowed to run from a higher potential metal to a lower one.



Design Considerations

The versatility of Solid Zinc Strip makes it ideal for exterior and interior architectural applications. Zinc's cool gray patina and natural surface blends beautifully with most building materials and surroundings, both in contemporary and traditional settings and environments.

Finishes

- Glacier Gray
- Glacier Gray TextureMatte™
- Onyx Black



Memory

Due to the mechanical nature of solid zinc strip, building products that rely upon compression fitting may not maintain tolerances and are not recommended. It is imperative that the profiles selected are mechanically seamed or otherwise engineered to stay in place.

Ventilation

United Zinc features a high-performance plastisol back coating to protect the material from interior surface corrosion. While a degree of ventilation is still recommended, IMETCO's United Zinc panels can typically be installed in the same manner as other metal roofing and wall systems. Commercially available zinc with no backside coating should be avoided, since the probability for corrosion is increased.

Contact your IMETCO representative for more information.

Roof Slope

To make sure the zinc is not subjected to ponding water, a minimum slope of 1:12 is recommended. The minimum slope required for specific roofing products varies; refer to the individual product's design guidelines for more information on minimum roof slopes.

The Natural Patina Process and Preweathered Finishes

Zinc's naturally forming cool gray patina provides ageless beauty and life-long protection. The natural patina is a layer of zinc-hydroxy carbonate, which forms when zinc comes in contact with water and carbon dioxide from the atmosphere. Typically, the patina begins to form in two to five years (except in arid climates where it may evolve over a longer period of time), and maintains a uniform color throughout the zinc's lifespan.

United Zinc's preweathered **Glacier Gray** finish immediately provides the designer with the look of a naturally appearing weathered patina. The cool gray tones utilized with the Glacier Gray finishing process most accurately resemble the innate patina appearance that all zinc products will, over time, inherently achieve.

The **TextureMatte™** finish provides a very fine and subtle surface quality, which is achieved through a roller-texturing process on the architectural zinc strip. TextureMatte material exhibits a matte finish luster and the appearance of improved flatness.

The United Zinc preweathered **Onyx Black** finish is achieved by a multi-step process which includes chemically reactive processes such as immersion in reactive baths, passivation treatments, and solid pigmentation application. The Onyx Black finish can be expected to retain its uniform dark coloration for decades.

Efflorescence is a normal weathering condition that sometimes occurs as a typical and generally temporary stage of the natural patina process, and is not a defect or cause for rejection.

While properly designed zinc cladding systems can provide many decades of successful performance in virtually all environments and geographical regions, please consult with the United Zinc technical support team to evaluate each specific application. In some infrequent and specific climatic conditions, other base metal materials may be recommended for certain specific cladding system applications.



Material Handling and Installation Guidelines

Forming

Zinc material temperature **must** be above 50°F before forming or bending (this includes pan-ending, turning down caps, and all other field bending operations). Using an infrared thermometer to measure material temperature is recommended. Coils, sheets and panels can be heated by using electric blankets with “moving pads” over the top of the blankets. However, avoid significant temperature variations when handling zinc, as this can cause condensation build-up that may cause white rust to form.

Avoid forming which incorporates severe reverse bending or which subjects the material to alternate compression and tension. The minimum forming bend radius shall be not less than 3T (3 times the sheet thickness) for sheet thicknesses .032” and thinner, and not less than 4T (4 times the sheet thickness) for sheet thicknesses over .032”.

Handling

Zinc sheets, coils, or formed pieces should be handled with care. Dropping, dragging or sliding the material can cause dings or surface abrasions, which could result in cracking or other damage to its appearance and/or structural integrity over time. Even though zinc will form a natural protective barrier, installers should take precautions during installation to make sure that no damage, deformities, or color variations occur. Installers should always wear gloves and long sleeved shirts when handling zinc, since perspiration and oils in the skin will leave marks on its surface. While these marks will heal over time, they will remain visible for a while, affecting aesthetic appearance of the zinc immediately after installation.

Construction Dust & Debris

While run-off from lime stone onto zinc is acceptable, the lime stone and gypsum dust created when cutting these materials can react with zinc when water is present to form a superficial layer of white rust. Any lime stone or gypsum dust must be cleaned from zinc. Use best practices to reduce the amount of dust and prevent white rust.

Packaging and Storage

To minimize the potential of white rust forming during transportation or staging, store zinc in dry places, and use packaging that allows water to evaporate quickly. Avoid significant temperature variations or humidity during transport.

Zinc products must be stored in a dry, sheltered, well-ventilated area to prevent condensation or water build-up on the material. Control temperature variations to avoid condensation build-up, and cover the ground below to help prevent moisture from rising up and condensing on the panels. Cover the material to prevent standing water, dirt, and construction debris from settling. However, a tarp is not recommended since it will cause condensation build-up. Plywood can be used with spacing between the plywood and the zinc to allow drainage and ventilation.

Stack panels horizontally (face-to-face with the panel’s pan in the horizontal plane), or vertically (face-to-face with the panel’s pan in the vertical plane), and brace with adequate support to maintain straight vertical or horizontal stacks. Stacked panels must have a high point at one end to provide a positive drain direction. Maximum horizontal stack height is 10 levels (one level consists of two nested panels). A single row of vertically stacked panels is the maximum allowable height.

Protective film should be removed from zinc panels upon completing an elevation, all at the same time in order to minimize color variations due to one section weathering faster than another. However, to protect zinc panels from contamination by other trades, the film can remain on the zinc for up to, but no more than, 60 days following installation. Avoid cutting film with a steel razor or knife. If cutting is required, use the sharp edge of a scrap piece of zinc.

Avoid contact with green or wet lumber, water or condensation, contact with or close proximity of damp insulation or other corrosive materials.

Maintenance and Cleaning

Debris such as dirt, leaves, and rubbish should be removed from overlaps and all other surfaces of the sheets or panels to avoid deterioration. Use a mild detergent and hot water with a soft rag to clean the zinc. Contact IMETCO for more information.

Caulks and Sealants

Polyurethane and certain other advance polymer caulks and sealants are compatible with zinc. Caulk or sealant must be able to withstand high temperatures for extended periods of time. Avoid caulks or sealants with an acidic cure, as they will corrode the zinc. Contact your IMETCO representative for more information.

Soldering

When soldering United Zinc, clean the surface with a solvent and apply flux sparingly. Allow time for the flux to react with the metal. A solution of zinc chloride can be used as a flux, which can also be mixed with ammonium chloride. Some proprietary non-acid fluxes are also available. The melting point of a good flux should be below that of the solder. If a non-corrosive flux is desired, as in electronic assemblies, faying surfaces must be pre-coated with solder. Use a 60/40 or 50/50 tin/lead solder. Antimony-bearing solder should not be used because it produces brittle joints. Apply heat and solder so that the joint faying surface is slightly abraded to begin fusing. Typically, neither preheating or pre-tinning are needed. Flame heating is not recommended. Do not heat the iron to redness or allow it to dwell in one spot - this may cause base metal to melt (zinc has a low melting point of 792° F).



Products Available in United Zinc

	Roof Systems			Wall Systems			Edge Systems				Coil/Flat Sheet
	Series 300	TwinLok	DLSS	Latitude	FW	PermWall	EZ Edge Coping	Fascia	PerformaEdge Coping	Fascia	
Gauge Availability											
0.7 mm (0.0276")		●	●	●	●	●		●			●
0.8 mm (0.0315")	●	●	●	●	●	●	●	●	●	●	●
1.0 mm (0.0394")	●			●	●		●	●	●	●	●
1.2 mm (0.0472")				●			●		●	●	●
1.5 mm (0.0591")				●			●		●		●
2.0 mm (0.0788")											●
Design Considerations											
Min. Slope (Roof Panels)	1:12	2:12	3:12								
Backside Coating Standard	●	●	●	●	●	●	●	●	●	●	●
Air Space/Ventilation Required	●	●	N/A	●							
Ventilation Mat (Roof Panels)	If < 4:12	If < 4:12	N/A								
Material Warranty	30 Year Limited Material Warranty Available										
Weathertightness Warranty ⁽¹⁾	●	●		●							
Avail. Width (Roof & Wall Panels)	12, 16	12, 16	12, 16	12, 16	12, 16	12					
Max. Length	Unlimited	30 feet	30 feet	20 feet	20 feet	20 feet	10 feet	10 feet	10 feet	10 feet	10 ft. & Coils
Testing ⁽²⁾											
ASTM E1592	●										
ASTM E1648	● ⁽³⁾										
ASTM E1680	● ⁽³⁾										
UL 580	● ⁽³⁾	●									
UL 1897		●									
ASTM E330				●		● ⁽³⁾					
ASTM E283				● ⁽³⁾		● ⁽³⁾					
ASTM E331				● ⁽³⁾		● ⁽³⁾					
ASTM E1886				● ⁽³⁾							
ASTM E1996				● ⁽³⁾							
TAS 125				● ⁽³⁾							
ANSI/SPRI ES-1									●	●	

¹ Please contact IMETCO for complete details and requirements for weathertightness warranties.

² Testing has not been conducted on all widths and gauges of material.

³ Testing has been conducted on profiles formed in steel and/or aluminum.

Contact your IMETCO representative for information about other products available with United Zinc.



Series 300® Symmetrical Seam Metal Roof

IMETCO's flagship product, the versatile Series 300 roof system offers strength, beauty, and efficiency. Series 300 is engineered to allow unlimited thermal movement, making it an ideal roofing system for zinc. It features a one-piece clip and a 2³/₈-inch symmetrical seam with a separate, easy-to-install mechanically seamed cap.

This remarkable structural panel adds dynamic visual impact while providing decades of protection from even the most severe weather conditions. It has been rigorously tested to be leakproof and to withstand hurricane-force winds. Its symmetrical design means that Series 300 can be installed starting from any point on the roof to produce a sleek, balanced, proportional look that complements any design.

United Zinc gauges available:

- 0.8 mm (0.0315")
- 1.0 mm (0.0394")

Warranty:

- Material Warranty
- Weathertightness Warranty

Testing*:

- AAMA 501.1
- ASTM E-1592, E-1646, E-1680, E-2140
- ENCON CN-240
- FM® 4471
- TAS 100-95, 114 (APP G), 125, 201, 203
- UL 263, 580

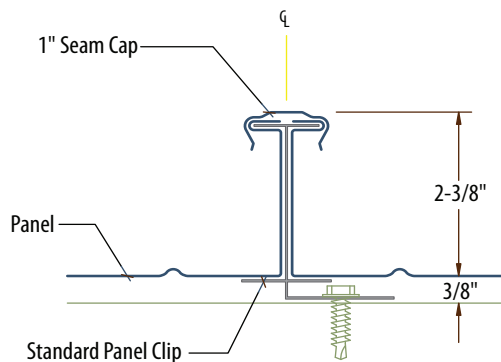

TwinLok Mechanically Seamed Metal Roof

IMETCO's TwinLok system offers an economical metal roofing option. Its interlocking panels are available with 1¹/₂-inch and 2-inch seam heights.

TwinLok is designed for use on slopes above 2:12 with a solid deck and underlayment. Its heavy concealed clips allow thermal movement. Center of panels can be striated or flat. Seams contain factory-applied hot-melt sealant.

United Zinc gauges available:

- 0.7 mm (0.0276")
- 0.8 mm (0.0315")

Warranty:

- Material Warranty
- Weathertightness Warranty

Testing*:

- ASTM E-283, E-331, E-1592
- UL 580, 1897

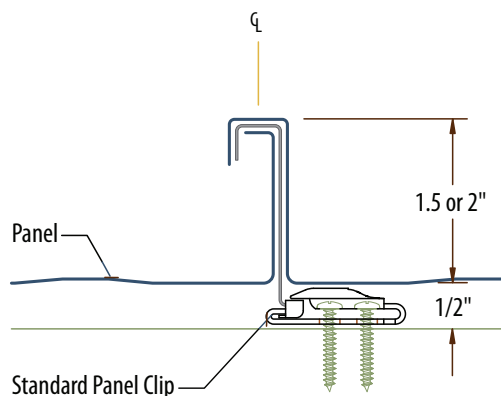

DLSS Architectural Metal Roof

IMETCO's Double Lock Standing Seam (DLSS) is a architectural double lock standing seam roof panel system for use on minimum slopes of 3:12. Its mechanically seamed interlocking panels are available with a 1-inch seam height. Available in a variety of coverage widths, gauges, and finishes, the traditional appearance of the DLSS system is especially well suited for historical renovations or other applications requiring a more traditional profile.

United Zinc gauges available:

- 0.7 mm (0.0276")
- 0.8 mm (0.0315")

Warranty:

- Material Warranty

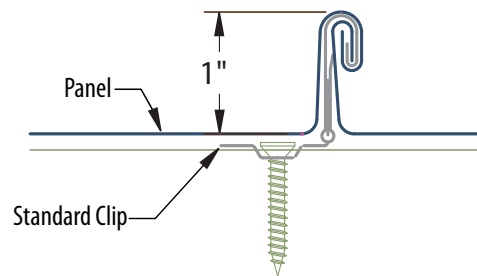

* Testing conducted on various materials and assemblies. Contact your IMETCO representative for more information.



Latitude™ Wall Panel Systems

The Latitude™ series from IMETCO is a high-performance exterior and interior metal wall system that provides dynamic visual impact and proven resistance to wind uplift and water infiltration.

Suitable for horizontal and vertical applications, the Latitude series features a wide variety of profile configurations that can be mixed and matched to provide visual interest. Concealed heavy-duty clips and fasteners allow unlimited thermal movement. PrecisionEdge™ factory mitered corners are available as an option.

United Zinc gauges available:

- 0.7 mm (0.0276")
- 0.8 mm (0.0315")
- 1.0 mm (0.0394")
- 1.2 mm (0.0472")
- 1.5 mm (0.0591")

Warranty:

- Material Warranty
- Weathertightness Warranty

Testing*:

- ASTM E-283, E-330, E-331, E-1886, E-1996

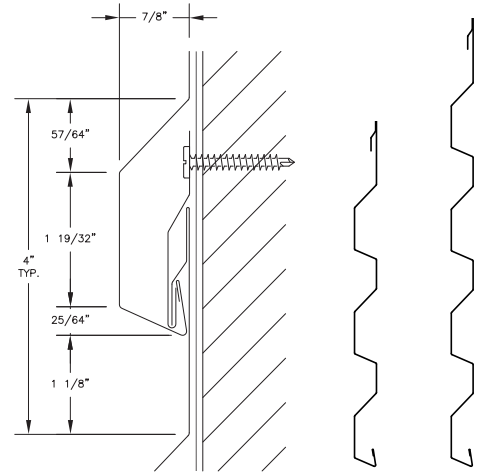

FW Metal Wall Panel Systems

IMETCO's FW wall panel is an attractive, cost-effective concealed-fastener metal wall and soffit system. This durable system offers aesthetic appeal and the tested assurance of IMETCO metal products in an easy-to-install wall panel. It features a 12-inch standard panel width with 1-inch deep (nominal) interlocking seams.

Profile choices include a smooth surface with no stiffening grooves, or two equally spaced V-grooves. Optional factory notching and end folds create a sleek, clean reveal on four sides.

United Zinc gauges available:

- 0.7 mm (0.0276")
- 0.8 mm (0.0315")
- 1.0 mm (0.0394")

- Material Warranty

Warranty:

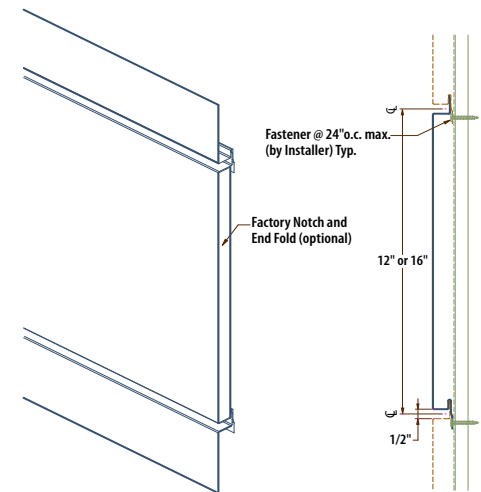

PermWall Flush Metal Wall System

IMETCO's PermWall 1.0 and 1.5 flush wall panel systems are engineered for strength and longevity, and designed for the beauty of smooth consistency. Concealed fasteners secure virtually invisible vertical seams that are tested and warranted to the high-performance and quality standards for which IMETCO products are renowned. PermWall systems are custom-formed by IMETCO's talented metal craftsmen to suit the unique requirements of each and every project.

United Zinc gauges available:

- 0.7 mm (0.0276")
- 0.8 mm (0.0315")

Warranty:

- Material Warranty

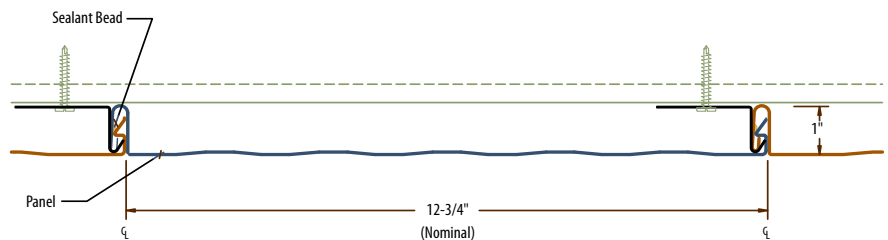

* Testing conducted on various materials and assemblies. Contact your IMETCO representative for more information.



PermaEdge and EZ Edge Fascia & Coping

PermaEdge Systems are engineered for performance, and fully tested based on the ANSI/SPRI ES-1 method to meet or exceed your specific project requirements. That's why our ES-F Series Fascia and ES-C Series Coping systems are among the strongest in the industry.

EZ Edge formed line combines quality with economy. These products offer proven reliability and pleasing aesthetics at a lower cost than performance-inspired edge systems.

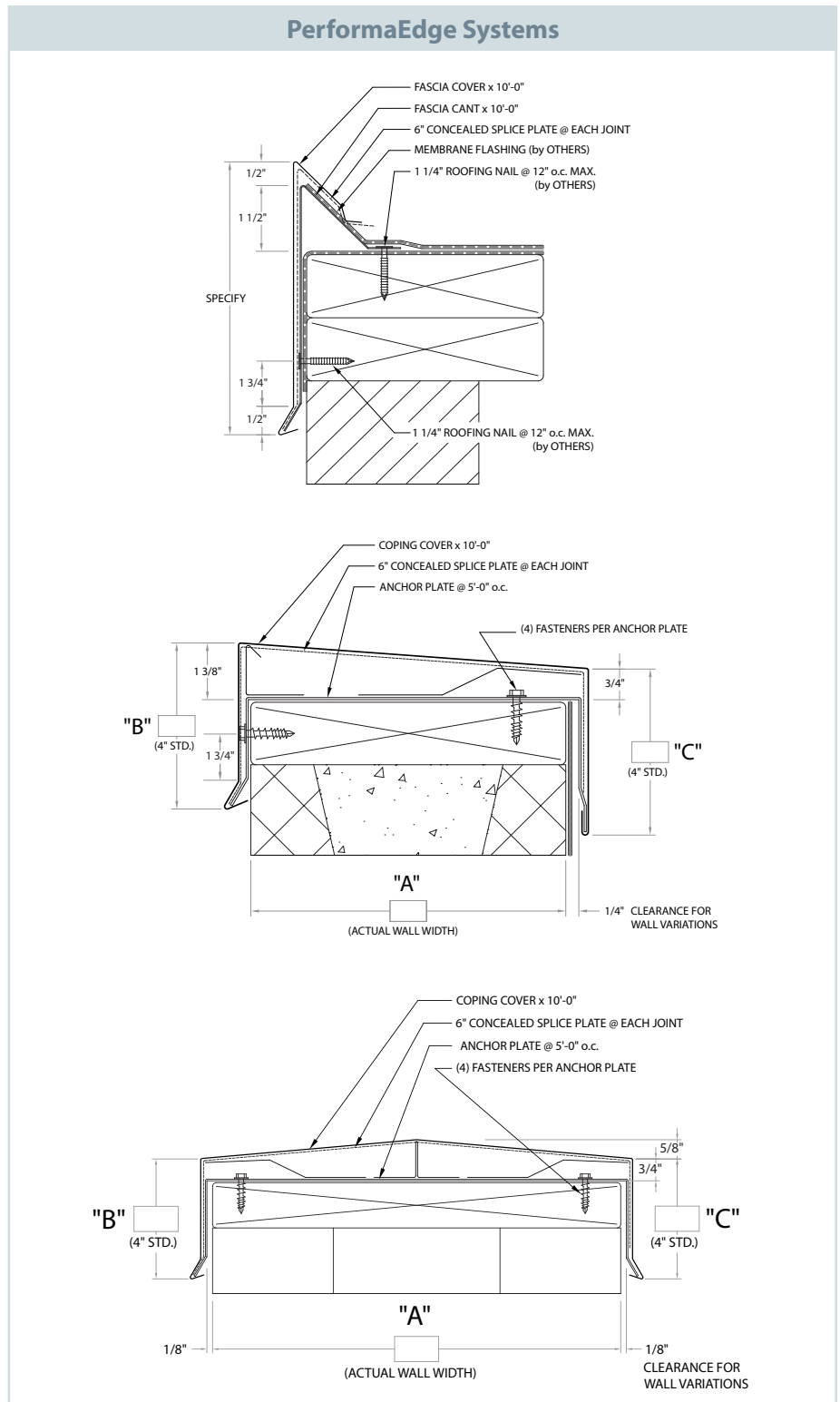
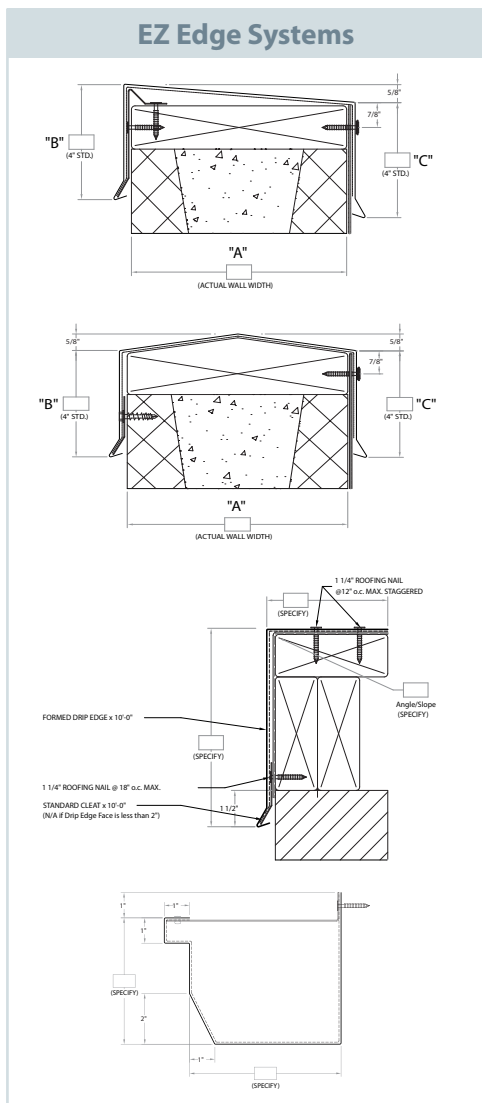



United Zinc and Sustainability

United Zinc is an environmentally safe, environmentally friendly material that is ideal for a wide variety of architectural applications. There are few materials that are as ecologically friendly as zinc. Readily found in the air, water, and soil, zinc is essential to life as we know it. It is a key element in every living thing, promoting cell growth and the production of proteins, which are the very building blocks of life itself.

LEED

United Zinc products contribute to achieving LEED points as follows:

LEED MR 2.1 - Construction Waste Management 1 point

All zinc construction waste can easily be separated from other materials for recycling. Zinc has a very high scrap value, and can be recycled indefinitely - not just once like other "recyclable" materials. Architectural zinc can be recovered and reprocessed into new architectural products. United Zinc, for example, contains more than 30% recycled content. Recycled zinc can also be used in galvanization.

LEED MR 4.1 - Recycled Content 1 point

More than 30% recycled zinc is used for United Zinc. All scrap generated during manufacturing is reclaimed and used as content for additional material.

LEED MR 5.1 - Regional Materials 1 point

United Zinc originates in Clarksville, TN, and is considered a regional material for projects within a 500 mile radius.



Environmental Considerations

Durability/lifespan

Zinc's longevity as a building material is not measured in years, but generations. While American usage of zinc roofing is more recent, zinc roofs in Europe have seen service lives of more than a century. It is reasonable to expect that zinc walls can last more than 100 years, and zinc roofs can last up to 100 years in rural areas, 70 years in coastal areas, and 40 years in heavily polluted industrial areas.

During its service life, zinc requires little maintenance, and continues to develop its protective patina which will self-repair any imperfections or scratches.

Recycled content

More than 30% of United Zinc's composition is from recycled material.

Recyclability

Upon completion of its useful service life, all United Zinc materials are 100% recyclable. Unlike some other recyclable building materials, zinc can be recycled again and again without losing its unique physical and chemical properties, which significantly reduces the need for new raw materials.

Energy demand (production)

The extraction and processing of zinc is extremely energy efficient. In fact, the amount of energy required to produce zinc from ore, and to process it into rolled zinc strip, is significantly less than that required by other metals used for building materials, such as aluminum, copper, and stainless steel.

Even less energy is required to produce zinc with recycled content, thus United Zinc, with its 30% recycled content, requires less energy to produce than other common zinc materials with less recycled content.

Run-off and Fungal Resistance

As a fungistat, United Zinc resists mold, mildew and fungus, but its run-off is clean, and will not harm desirable vegetation like other exotic metals can.



2070 Steel Drive | Tucker, GA 30084
www.imetco.com | (800) 646-3826

© Copyright 2010 Innovative Metals Company, Inc.